

Instruction Manual

E1M175S, E1M275S, E2M175S and E2M275S Rotary Vacuum Pumps

<i>Description</i>	<i>Item Number</i>
<i>E1M175S Rotary Vacuum Pump, 200 V, 50 Hz/200-210 V, 60 Hz, three-phase</i>	<i>A346-01-934</i>
<i>E1M175S Rotary Vacuum Pump, 220-240/380-415 V, 50 Hz, three-phase</i>	<i>A346-01-935</i>
<i>E1M175S Rotary Vacuum Pump, 230/460 V, 60 Hz, three-phase</i>	<i>A346-03-982</i>
<i>E2M175S Rotary Vacuum Pump, 200 V, 50 Hz/200-210 V/380 V, 60 Hz, three-phase</i>	<i>A366-01-934</i>
<i>E2M175S Rotary Vacuum Pump, 220-240/380-415 V, 50 Hz, three-phase</i>	<i>A366-01-935</i>
<i>E2M175S Rotary Vacuum Pump, 230/460 V, 60 Hz, three-phase</i>	<i>A366-03-982</i>
<i>E1M275S Rotary Vacuum Pump, 200 V, 50 Hz/200-210 V/380 V, 60 Hz, three-phase</i>	<i>A347-01-934</i>
<i>E1M275S Rotary Vacuum Pump, 220-240/380-415 V, 50 Hz, three-phase</i>	<i>A347-01-935</i>
<i>E1M275S Rotary Vacuum Pump, 230/460 V, 60 Hz, three-phase</i>	<i>A347-03-982</i>
<i>E2M275S Rotary Vacuum Pump, 200 V, 50 Hz/200-210 V/380 V, 60 Hz, three-phase</i>	<i>A367-01-934</i>
<i>E2M275S Rotary Vacuum Pump, 220-240/380-415 V, 50 Hz, three-phase</i>	<i>A367-01-935</i>
<i>E2M275S Rotary Vacuum Pump, 230/460 V, 60 Hz, three-phase</i>	<i>A367-03-982</i>



Manor Royal, Crawley, West Sussex, RH10 2LW, UK
Telephone: +44 (0) 1293 528844 Fax: +44 (0) 1293 533453
<http://www.bocedwards.com>

Declaration of Conformity

We, BOC Edwards,
Manor Royal,
Crawley,
West Sussex RH10 2LW, UK

declare under our sole responsibility that the product(s)

E1M175, E2M175, E1M275 and E2M275 Rotary Vacuum Pumps

A346-01-935	A366-01-935	A367-01-935
A346-03-982	A366-03-982	A367-03-982
A347-01-935	A366-15-935	A347-03-982
A366-16-982		

to which this declaration relates is in conformity with the following standard(s)
or other normative document(s)

EN ISO 12100-2: 2003	Safety of Machinery – Basic Concepts, General Principles for Design.
IEC 34 Parts 1, 5, 8†: 1991	Central Requirements for Rotating Electrical Machines.
† 3-phase pumps only.	

following the provisions of

73/023/EEC	Low Voltage Directive.
89/336/EEC	Electromagnetic Compatibility Directive.
98/37/EC	Machinery Safety Directive.

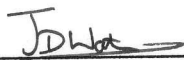

Dr. J. D. Watson, Director of Technology,
Vacuum Equipment and Exhaust Management Product Divisions

8 DECEMBER 2004 SHORHAM

Date and Place

This product has been manufactured under a quality system registered to ISO9001

CONTENTS

Section	Title	Page
1	INTRODUCTION	1
1.1	Scope and definitions	1
1.2	Description	3
1.3	Gas-ballast	4
2	TECHNICAL DATA	5
2.1	Operating and storage conditions	5
2.2	Performance	5
2.3	Mechanical data	8
2.4	Electrical data: three-phase motors	8
2.5	Lubrication data	9
3	INSTALLATION	10
3.1	Safety	10
3.2	System design considerations	11
3.3	Unpack and inspect	11
3.4	Locate the pump	12
3.5	Connect the pump to the cooling water	12
3.6	Fill the pump with oil	12
3.6.1	Recommended pump oils	12
3.6.2	Filling procedure	13
3.7	Electrical installation	14
3.7.1	Connect the pump to your electrical supply	14
3.7.2	Check the direction of rotation	15
3.8	Connect the pump inlet to your system	16
3.9	Connect the pump outlet to your system	16
3.10	Gas-ballast inlet connection	17
3.11	Leak-test the system	17
4	OPERATION	18
4.1	Gas-ballast control	18
4.2	Start-up procedure	18
4.3	To achieve ultimate vacuum	19
4.4	To pump condensable vapours	19
4.5	To decontaminate the oil	19
4.6	Unattended operation	20
4.7	Shut-down	20
5	MAINTENANCE	21
5.1	Safety	21
5.2	Maintenance plan	22
5.3	Check the oil-level	22
5.4	Replace the oil	23
5.5	Clean the fine oil-filter	24
5.6	Replace the gas-ballast filter	25
5.7	Inspect and clean the inlet-filter	26

Section	Title	Page
5.8	Clean the motor fan-cover	27
5.9	Clean and overhaul the pump	27
5.10	Test the motor condition	27
5.11	Fit new blades	27
5.12	Basic fault-finding	27
5.12.1	The pump has failed to start	27
5.12.2	The pump fails to achieve its specified performance	28
5.12.3	The pump is noisy	28
5.12.4	The pump is too hot	28
5.12.5	The vacuum is not fully maintained after the pump is switched off	29
5.12.6	The pumping speed is poor	29
5.12.7	There is an external oil leak	29
6	STORAGE AND DISPOSAL	30
6.1	Storage	30
6.2	Disposal	30
7	SERVICE, SPARES AND ACCESSORIES	31
7.1	Introduction	31
7.2	Service	31
7.3	Spares	31
7.4	Accessories	32
7.4.1	Inlet dust-filter	32
7.4.2	Inlet catchpot	32
7.4.3	High-capacity inlet dust-filter	32
7.4.4	Inlet chemical-trap	32
7.4.5	Outlet catchpot	33
7.4.6	Outlet mist-filter (clean applications)	33
7.4.7	External oil filter	33
7.4.8	Solenoid-operated gas-ballast control valve	34
7.4.9	Thermostatic control valve	34
7.4.10	Vibration isolators	34

Illustrations

Figure	Title	Page
1	The E1M175 and E2M175 pump	2
2	Dimensions E1M175S and E2M175S (mm)	6
3	Dimensions E1M275S and E2M275S (mm)	7
4	Oil level indication	13
5	Electrical supply connection, three-phase motors, 200 V 50 Hz, 200-210 V 60 Hz, 220-240 V 50 Hz or 230 V 60 Hz	14
6	Electrical supply connection, three-phase motors, 380-415 V 50 Hz, 380 V 60 Hz or 460 V 60 Hz	15
7	Remove and replace filter-element	24
8	Remove and replace gas-ballast filter-elements	25
9	Remove and replace inlet-filter	26
10	Accessories	35

Tables

Table	Title	Page
1	Electrical data	8
2	Maintenance plan	22

Associated Publications

Publication title	Publication Number
Vacuum pump and vacuum system safety	P300-20-000
Ultragrade 15, 19 and 20 oils	P110-10-010
Vibration isolators	A248-01-880
Oil return kits, MF100 and 300 (for E1M40 to E2M275 pumps)	A500-04-880
EOF300 external oil filter	A500-09-880
EBV100S, 300D and 300S gas ballast valves	A500-18-881
EOF external oil filtration system	A540-01-880
EOF adapter kit for E1M/E2M175 and 275	A540-36-880
IT20K, IT100, IT300 and IT800 inlet traps and filters	A441-01-880
MF mist filters and CP catchpots	A461-03-880

This page intentionally blank

Pumps International
www.PumpsInt.com

1 INTRODUCTION

1.1 Scope and definitions

This manual provides installation, operation and maintenance instructions for the BOC Edwards E1M175S, E1M275S, E2M175S, and E2M275S Rotary Vacuum Pumps. You must use your pump as specified in this manual. Read this manual before you install and operate your pump.

Important safety information is highlighted as WARNING and CAUTION instructions; you must obey these instructions. The use of WARNINGS and CAUTIONS is defined below.

	<p style="text-align: center;">WARNING</p> <p>Warnings are given where failure to observe the instruction could result in injury or death to people.</p>
---	---

<p style="text-align: center;">CAUTION</p> <p>Cautions are given where failure to observe the instruction could result in damage to the equipment, associated equipment and process.</p>

The units used throughout this manual conform to the SI international system of units of measurement.

The following warning symbol is on the pump:



Caution - refer to accompanying documents.



Caution - risk of electric shock.



Caution - hot surface

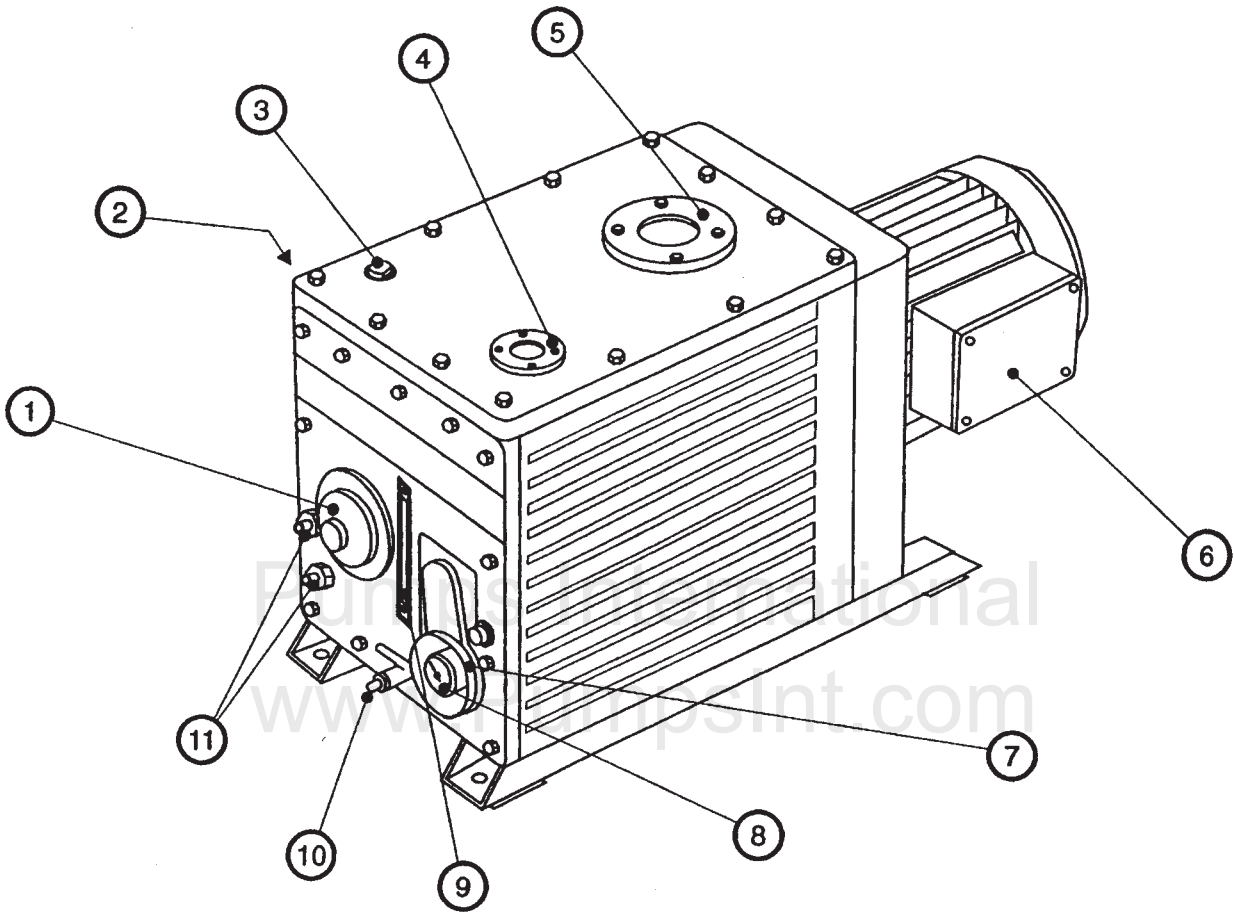

- | | |
|------------------------------------|-------------------------------|
| 1. Gas-ballast control | 7. Oil-filter location |
| 2. External oil-filter connections | 8. Oil pressure-gauge |
| 3. Oil filler-plug | 9. Oil-level sight-glass |
| 4. Outlet-port | 10. Oil drain-tap |
| 5. Inlet-port | 11. Cooling-water connections |
| 6. Motor terminal-box | |

Figure 1 - The E1M175 and E2M175 pump

1.2 Description

The BOC Edwards rotary vacuum pump is shown in Figure 1. Refer to Figure 1 for item numbers in brackets in the following descriptions.

The E1M175S, E1M275S, E2M175S and E2M275S pumps are single or two-stage oil-sealed, high-vacuum pumps designed for reliable, long-term operation in both laboratory and industrial environments. A four-pole three-phase motor provides direct-drive through a flexible coupling. The pumps are free-standing mounted on steel runners.

The E1M (single-stage) pumps have a high-vacuum rotor and stator assembly with integral sliding-vane oil-pump. The E2M (two-stage) pumps have an additional low-vacuum rotor and stator assembly.

Lubrication is provided by a sliding-vane oil pump. Oil is drawn into the pump through a wire mesh strainer. The oil is pumped to a spring-loaded distributor valve. The distributor valve directs a lightly-pressurised supply of oil to the main vacuum-pump and by-passes the excess back to the oil reservoir. Some of the excess oil is re-directed through a large area, fine-pore filter and some through a relief-valve. When the pump is switched off, the spring-loaded distributor valve provides oil and air suckback protection. On single-stage pumps you can obtain additional air suckback protection by using a solenoid-operated valve at the gas-ballast port. Refer to Section 1.3.

You can inspect the level and condition of oil in the oil box through an oil-level sight-glass (9). An oil filler-plug (3) is fitted at the top of the oil box. An oil drain-tap (10) is fitted at the bottom of the oil box.

The pump has an inlet-port (5) with an ISO63 flange and an outlet-port (4) with an ISO40 flange. Connections for an external oil-filter are provided (2) (these are not shown in Figure 1); external oil-filter (outlet) is the top connection and the external oil-filter (return) is the lower connection.

The gas-ballast control (1) allows you to control the introduction of gas-ballast when pumping high vapour loads. Refer to Section 1.3 for more information about gas-ballast.

Your pump is water cooled. BOC Edwards recommend that you use a thermostatic controlled valve to regulate water flow. This will ensure optimum pump working temperature, maintain economies in water use, and provide assistance with gas-ballast protection. The thermostatic control valve is an accessory, refer to Section 7.

Refer to Section 7 for details about vibration isolators and other recommended accessories.

1.3 Gas-ballast

	<p style="text-align: center;">WARNING</p> <p>Do not use the E1M175 or the E1M275 to pump hazardous process gases. Process gases may leak to atmosphere through the permanent air bleed in the gas-ballast assembly. Hazardous gases could cause injury to people or damage the equipment.</p>
---	---

To pump high vapour loads, gas-ballast is delivered into the pump to prevent condensation of the vapour carried by the pumped gases. This system reduces oil contamination and pump corrosion caused by condensed vapour from the pumped gases.

You can introduce air or an inert gas into the low vacuum stage of the pump through the gas-ballast inlet (Figure 1, item 1). A filter/silencer is fitted in the gas-ballast system, to prevent the entry of dust into the pump and to improve silencing. You can control the gas-ballast either manually or remotely.

Note that the E1M175S and E1M275S pumps have a permanent bleed through the gas-ballast inlet.

For manual control, use the gas-ballast control (Figure 1, item 1). The pumps are supplied with an open-gas-ballast inlet. If you leave this inlet open to the atmosphere, then:

- With the gas-ballast control (Figure 1, item 1) open, when you switch the pump off, the pressure inside the pump will rise to atmospheric pressure.
- With the gas-ballast control closed, when you switch the pump off:
 - E1M175S and E1M275S: the pressure inside the pump will slowly rise to atmospheric pressure. (To maintain the vacuum inside the pump, fit a solenoid operated gas-ballast control valve.)
 - E2M175S and E2M275S: the vacuum will be maintained inside the pump.

For remote control, fit a solenoid-operated gas-ballast control valve (available as an accessory from BOC Edwards, refer to Section 7) to the gas-ballast inlet and open the gas-ballast control. Connect the gas-ballast valve to your control system so that the valve is closed when the pump is switched off and if the electrical supply to the pump is interrupted. Under these circumstances, when the pump is switched off, the vacuum will be maintained inside the pump.

It should be noted that when the pump is switched off the system pressure is unaffected by the operation of the gas ballast. The vacuum is maintained in the system by closing the pump inlet valve.

For more information about the use of gas-ballast, refer to Sections 3.10 and 4.1.

2 TECHNICAL DATA

2.1 Operating and storage conditions

Ambient temperature range (operation)	12 to 40°C
Normal surface temperature of the pump body at ultimate vacuum ambient temperature of 20°C	50 to 70°C
Maximum humidity (operation)	90% RH
Ambient temperature range (storage)	-30 to 70°C

2.2 Performance

Note: Where total pressures are shown in the technical data tables, measurements were taken using an untrapped total pressure capacitance diaphragm gauge on a header, as specified by Pneurop standards.

	E1M175S	E2M175S	E1M275S	E2M275S
Maximum Displacement (m ³ h ⁻¹)				
50 Hz electrical supply	178	178	292	292
60 Hz electrical supply	214	214	350	350
Maximum Speed – Pneurop (m ³ h ⁻¹)				
50 Hz electrical supply	160	160	255	255
60 Hz electrical supply	196	196	306	306
Motor rotational speed r.min ⁻¹				
50 Hz electrical supply	1,440	1,440	1,440	1,440
60 Hz electrical supply	1,720	1,720	1,720	1,720
Ultimate vacuum mbar (Pa)				
without gas-ballast (partial pressure)	5 × 10 ⁻² (5)	10 ⁻⁴ (10 ⁻²)	5 × 10 ⁻² (5)	10 ⁻⁴ (10 ⁻²)
without gas-ballast (total pressure)	5 × 10 ⁻² (5)	1 × 10 ⁻³ (1 × 10 ⁻¹)	5 × 10 ⁻² (5)	1 × 10 ⁻³ (1 × 10 ⁻¹)
with full gas-ballast (partial pressure)	4 × 10 ⁻¹ (4 × 10 ¹)	5 × 10 ⁻³ (5 × 10 ⁻¹)	4 × 10 ⁻¹ (4 × 10 ¹)	5 × 10 ⁻³ (5 × 10 ⁻¹)
Maximum permitted outlet pressure (at full pump throughput) bar gauge (Pa)	0.5 (1.5 × 10 ⁵)	0.5 (1.5 × 10 ⁵)	0.5 (1.5 × 10 ⁵)	0.5 (1.5 × 10 ⁵)
Maximum water vapour inlet pressure without thermostatic water flow valve mbar (Pa)	50 (5 × 10 ³)	4 (4 × 10 ²)	50 (5 × 10 ³)	2 (2 × 10 ²)
with thermostatic water flow valve mbar (Pa)		20 (2 × 10 ³)		12 (12 × 10 ²)
Maximum water vapour pumping rate kgh ⁻¹	5.8	2.4	9.2	2.5
Maximum gas-ballast flow m ³ h ⁻¹	12	3	18	3

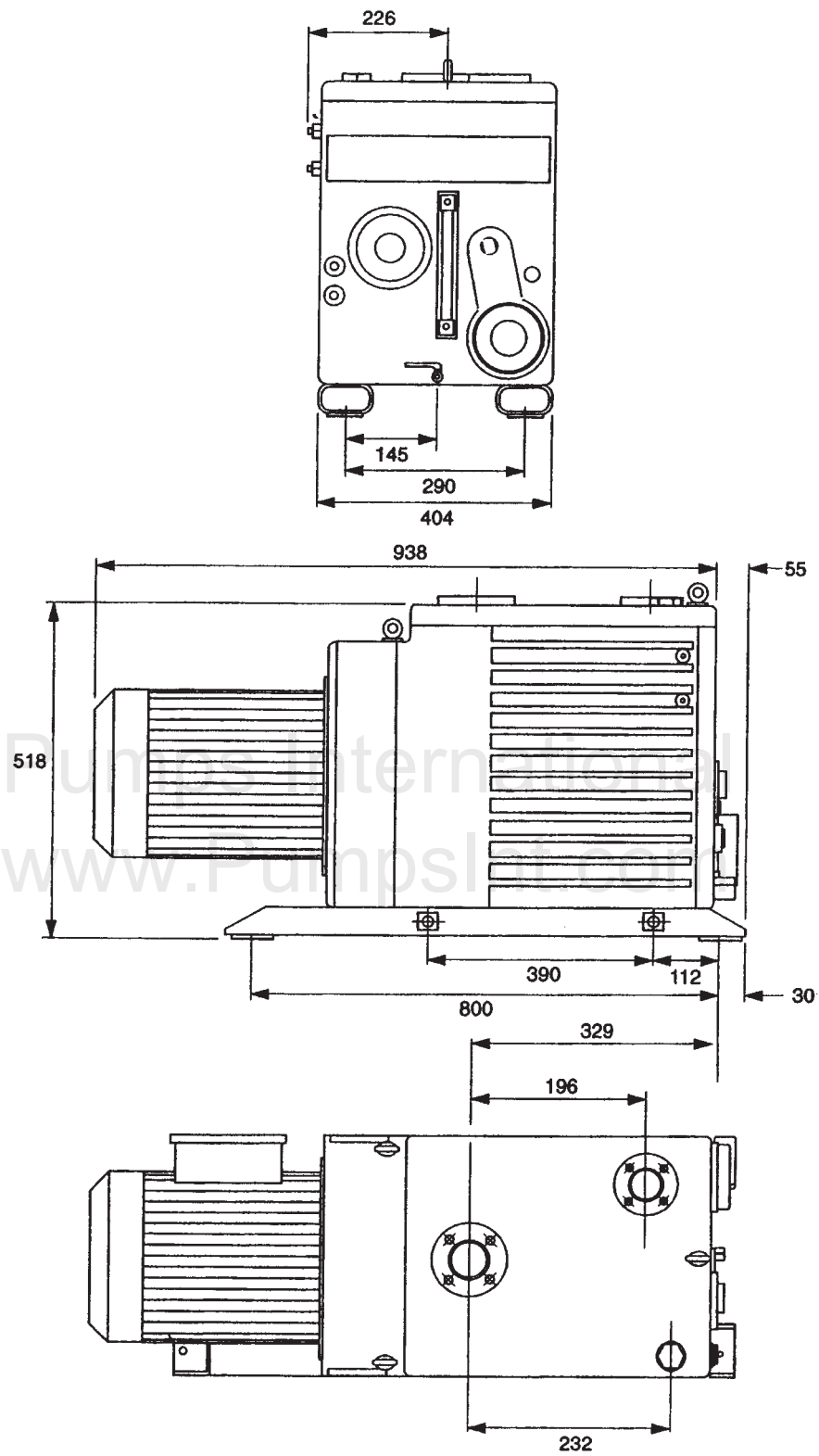

Figure 2 - Dimensions E1M175S and E2M175S (mm)

2.3 Mechanical data

Overall dimensions	See Figure 2 (E1M175S and E2M175S pumps) and Figure 3 (E1M275S and E2M275S pumps)
Degree of protection (IEC 34-5:1981)	IP55
Pump inlet-port	ISO63 (flange with trapped 'O' ring)
Pump outlet-port	ISO40 (flange centre tapped 1½ in. BSP)
Noise level at 1 metre (dB(A))	75

	E1M175S	E2M175S	E1M275S	E2M275S
Maximum mass (kg)	194	200	220	225

2.4 Electrical data: three-phase motors

Refer to the data in Table 1. You can configure the dual voltage motors to operate with either the high range or low range electrical supply: refer to the diagram specified in Table 1. Dual voltage motors are supplied preset to the highest of the selectable voltages.

When you start a cold pump, the motor draws the start-up current listed in Table 1 for less than one second. Within five minutes, as the oil in the pump warms up, the current drawn slowly reduces to the full-load current specified in Table 1.

When you restart a hot pump, the motor draws the start-up current specified in Table 1 for up to 0.5 seconds. The current drawn then immediately falls to the full-load current value.

Pump	Nominal supply (V)	Frequency (Hz)	Power (kW)	Full load current (A)	Start-up current (A)	Recommended fuse rating (A)*	Electrical supply connection, Figure
E1M175S or E2M175S	200	50	5.5	23	143	63	4
	200-210	60	6.5	25	150	63	4
	380	60	6.5	13.0	90	40	5
E1M275S or E2M275S	200	50	7.5	31	180	100	4
	200-210	60	8.5	32	186	100	4
	380	60	8.5	16.9	106	63	5
E1M175S or E2M175S	220-240	50	5.5	19.5	118	60	4
	380-415	50	5.5	11.4	68	35	5
E1M275S or E2M275S	220-240	50	7.5	26.8	160	100	4
	380-415	50	7.5	15.5	93	50	5
E1M175S or E2M175S	230	60	6.5	24.2	145	80	4
	460	60	6.5	11.5	69	40	5
E1M275S or E2M275S	230	60	8.5	31.8	186	100	4
	460	60	8.5	15	93	50	5

* You may need to use a different fuse rating. Use the information supplied with your circuit breaker or starter to select the correct fuse rating.

Table 1 - Electrical data

2.5 Lubrication data

Note: An BOC Edwards Health and Safety Data Sheet for the following oil is available on request.

Recommended oil*	Ultragrade 70			
	E1M175S	E2M175S	E1M275S	E2M275S
Oil capacity (litres)				
Maximum	25	25	28	28
Minimum	16	16	18	18

* To operate your pump when the ambient temperature is outside the limits specified in Section 2.1, or to optimise your pump performance when you pump condensable vapours, you may need to use a different oil.

Pumps International
www.PumpsInt.com

3 INSTALLATION

3.1 Safety

	<p style="text-align: center;">WARNING</p> <p>If you use a hydrocarbon oil in this pump, you must not use the pump to process oxygen in concentrations greater than 25% in volume. If you do, there is a risk of fire or explosion in the oil-box of the pump.</p>
---	---

	<p style="text-align: center;">WARNING</p> <p>We do not recommend that you use the E1M175S, E2M175S, E1M275S and E2M275S pumps to pump hazardous substances.</p>
---	---

You must ensure that the pump is suitable for your application. If you have any doubt about the suitability of the pump for your application, refer to the BOC Edwards guidelines on vacuum pump and vacuum system safety. (See Associated Publications at the end of the contents list).

Obey the safety instructions listed below when you install the pump, especially when you connect the pump into an existing system. Details of specific safety precautions are given at the appropriate point in the instructions.

- The installation of your pump must be performed by a suitably trained and supervised technician.
- Wear the appropriate safety-clothing when you come into contact with contaminated components.
- Vent and purge your vacuum system before you start installation work.
- Ensure that the installation technician is familiar with the safety procedures which relate to the pump-oil and the products handled by the pumping system. Take suitable precautions to avoid the inhalation of oil mist and excessive skin contact with pump-oil, as prolonged exposure can be harmful.
- Disconnect the other components in the pumping system from the electrical supply so that they cannot be operated accidentally.

3.2 System design considerations

Consider the following points when you design your pumping system:

- Use a suitable valve to isolate the pump from your vacuum system if you need to allow the pump to warm up before you pump condensable vapours or if you need to maintain vacuum when the pump is switched off.
- Avoid high levels of heat input to the pump from the process gases, otherwise the pump may overheat and seize.
- If you use the pump in a high ambient temperature and have a high gas throughput, the temperature of the pump-body may exceed 70°C. You must fit suitable guards to prevent contact with hot surfaces.
- Make sure that the exhaust pipeline cannot become blocked. If you have an exhaust-isolation valve, make sure that you cannot operate the pump with the valve closed.
- Provide for a purge of inert gas when you shut down the pumping system, to dilute dangerous gases to safe concentrations. A suitable solenoid operated gas-ballast control valve for introduction of purge-gas into the pump is available as an accessory (see Section 7).
- Ensure that a suitable supply of cooling water is available.

3.3 Unpack and inspect

Remove all packing materials, remove the pump from its packing-box, remove the protective covers from the inlet and outlet-ports and inspect the pump. If the pump is damaged, notify your supplier and the carrier in writing within three days; state the Item Number of the pump together with your order number and your supplier's invoice number. Retain all the packing materials for inspection. Do not use the pump if it is damaged.

If the pump is not to be used immediately, replace the protective covers. Store the pump in suitable conditions, as described in Section 6.1.

3.4 Locate the pump

	<p style="text-align: center;">WARNING</p> <p style="text-align: center;">Use suitable lifting equipment to move the pump. The mass of the pump is between 194 kg and 225 kg.</p>
---	--

Attach your mechanical lifting equipment to the lifting eyes on the pump.

Provide a firm, level platform for the pump. Locate the pump so that the oil-level sight-glass is visible and the oil filler-plug, oil drain-tap, disposable oil-filter and gas-ballast control are accessible. You must ensure that at least 330 mm is allowed, to withdraw the oil-filter from the pump.

If your pump will be located inside an enclosure, make sure that there is adequate ventilation at both ends of the pump. There must be a minimum space of 25 mm between the pump and the enclosure walls.

3.5 Connect the pump to the cooling water

Connect the two $\frac{3}{8}$ in. BSP internally threaded connections to the cooling water supply. The maximum pressure that can be admitted to the cooling circuit is 3 bar and the recommended minimum cooling water supply flow rates at 20°C are:

E1M175 & E2M175	80 l h ⁻¹
E1M275 & E2M275	120 l h ⁻¹

Your pump will reach optimum operating temperature and will operate more efficiently if the temperature is controlled by the TCV300 thermostatic control valve. The control valve is available as an accessory – see Section 7. A mounting point for the thermostatic probe is provided on the pump end-plate.

3.6 Fill the pump with oil

3.6.1 Recommended pump oils

It is recommended that you use BOC Edwards Ultragrade 70 oil as supplied with your pump. The ultimate vacuum of the pump with other oils may be higher than the ultimate vacuum with the Ultragrade 70 oil. However, note that other oils may contain polymers which may be degraded during use so that they become thinner. You will, therefore, have to change the oil more frequently than when you use BOC Edwards oils. If necessary, adjust the maintenance schedule according to your experience.

If you pump oxygen or other dangerous gases and vapours, you must use a chemically inert and stable oil (such as perfluoropolyether). For information on pumping dangerous gases and vapours, refer to the BOC Edwards guidelines on vacuum pump and vacuum system safety (see Associated Publications at the end of the contents list).

3.6.2 Filling procedure

Fill the pump with oil as described below. Refer to Figure 1 for the item numbers in brackets.

1. Remove the oil filler-plug (3).
2. Pour oil into the pump until the oil-level just reaches the MAX mark indicated on the bezel at the top of the sight-glass (9). If the oil-level goes above the MAX mark, open the oil drain-tap (10) and drain the excess oil from the pump.
3. After a few minutes, recheck the oil-level. If the oil-level is now below the MAX mark, pour more oil into the pump.

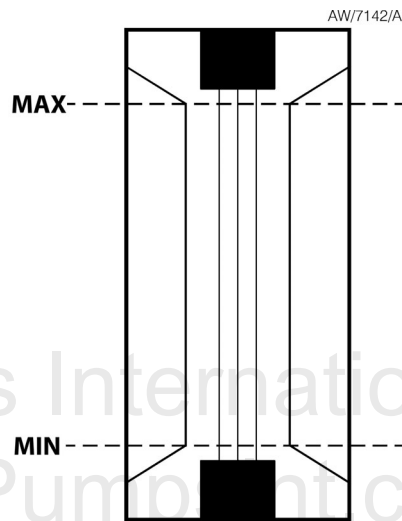

4. Refit the oil filler-plug. Tighten the plug firmly by hand. Do not over-tighten.

Figure 4-Oil level indication

3.7 Electrical installation

3.7.1 Connect the pump to your electrical supply

	WARNING
Ensure that the electrical installation of your pump-motor conforms with your local and national safety requirements. It must be connected to a suitably fused and protected electrical supply and a suitable earth point.	

CAUTION
If your pump-motor can be used with more than one voltage range, you must ensure that the motor is configured for your electrical supply voltage. If you do not, you may damage the motor.

Note: The pump will restart automatically when the electrical supply is restored after an interruption. If you do not want the pump to restart automatically, use electrical control equipment which must be reset manually.

We recommend that you connect the electrical supply to the motor through a starter or circuit breaker which has thermal over-current protection which can be adjusted to suit the full-load current ratings shown in Table 1. The fuse ratings in Table 1 are provided for guidance only. The supplier of your thermal over-current protection device may specify different values to ensure correct operation of the over-current protection device. Ensure that the fuse you use is suitable for the starting currents given in Table 1.

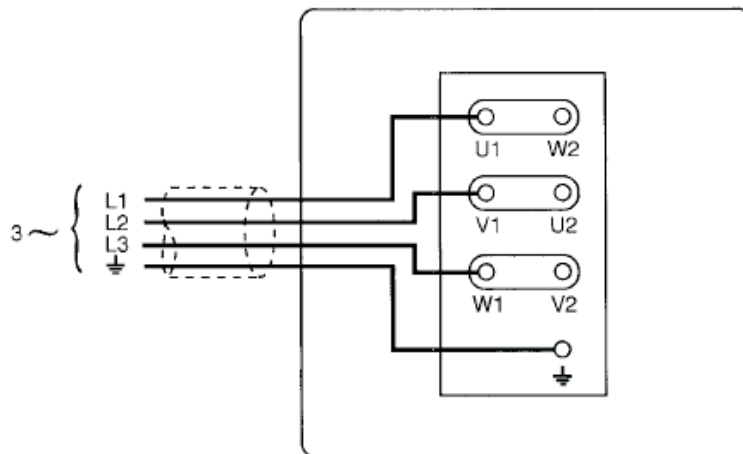

Figure 5-Electrical supply connection, three-phase motors, 200 V 50 Hz, 200-210 V 60 Hz, 220-240 V 50 Hz or 230 V 60 Hz

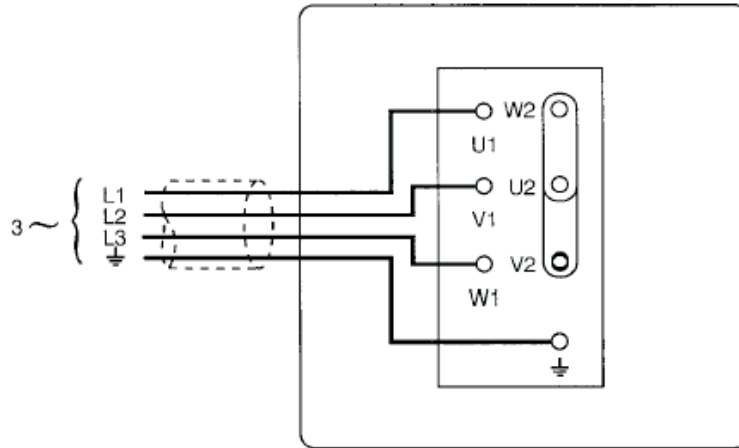

Figure 6 -Electrical supply connection, three-phase motors, 380-415 V 50 Hz, 380 V 60 Hz or 460 V 60 Hz

1. Remove the cover from the motor terminal-box.
2. Check your electrical supply voltage and frequency. If necessary, configure the motor to operate with your electrical supply (see Figures 5 and 6).
3. Remove the plugs from the cable-entry hole that you will use for the electrical supply cable. Choose the most suitable hole for your application.
4. Fit a suitable cable-gland and nut to the entry hole. After the supply cable is fitted, the cable-gland must be a protective seal to the standard of IP55 in IEC 529 or better.
5. Pass the motor electrical supply cable through the cable-gland.
6. Connect the cables to the terminals as shown in Figures 5 and 6.

3.7.2 Check the direction of rotation

CAUTION

Ensure that the pump-motor rotates in the correct direction. If it does not, the pump and your vacuum system can become pressurised.

1. Watch the motor cooling-fan through the motor fan-cover.
2. Switch-on the electrical supply to the motor for a few seconds and switch off.
3. Check that the motor cooling-fan rotates in the direction shown by the arrow on the motor mounting-plate. If the direction of rotation is incorrect:
 - Isolate the pump from the electrical supply
 - Remove the terminal-box cover and swap wires L1 and L3 (see Figures 5 and 6).
 - Refit the cover to the terminal-box
 - Connect the pump to the electrical supply
 - Check the direction of rotation again.

3.8 Connect the pump inlet to your system

Connect your vacuum system to the inlet-port (Figure 1, item 5). Use standard 63 mm fittings when you connect the pump.

Take note of the following information when you connect the pump to your vacuum system. Refer to Section 7 for details of the accessories mentioned below.

- For optimum pumping speeds, ensure that the pipeline connected to the inlet-port is as short as possible and has an internal diameter not less than the inlet-port diameter.
- Support the vacuum pipelines to prevent loading of the coupling-joints.
- If necessary, incorporate flexible bellows in your system pipelines to reduce the transmission of vibration and to prevent loading of coupling-joints. If you use flexible bellows, you must ensure that you use bellows which have a maximum pressure rating which is greater than the highest pressure that can be generated in your system. You must use flexible bellows if your pump is mounted on vibration isolators. We recommend that you use BOC Edwards flexible bellows.
- Use a suitable valve to isolate the pump from your vacuum system if you need to pump condensable vapours or maintain vacuum when the pump is switched off.
- Use a suitable inlet catchpot if you pump condensable vapours or if you use the pump for very dusty applications.
- Ensure that sealing surfaces are clean and scratch-free.

3.9 Connect the pump outlet to your system

	<p style="text-align: center;">WARNING</p> <p>Connect the pump outlet to a suitable treatment plant to prevent the discharge of dangerous gases and vapours to the surrounding atmosphere. Use a catchpot to prevent the drainage of contaminated condensate back into the pump.</p>
---	---

Connect the pump outlet-port to your outlet accessories or your exhaust treatment plant using standard fittings to connect to the ISO40 flange.

Take note of the following information before you connect to the pump outlet. Refer to Section 7 for details of the accessories mentioned below.

- The exhaust system must be configured so that the maximum pressure at the pump outlet does not exceed 0.5 bar gauge (1.5 bar absolute, 1.5×10^5 Pa) at full pump throughput.
- In the following circumstances, we recommend that you fit an oil mist filter to the pump outlet:
 - if you use the pump with the gas-ballast control open
 - if you operate the pump with an inlet pressure greater than 10 mbar for extended periods or
 - if you frequently pump down from atmospheric pressure.

The mist filter will trap the oil exhausted from the pump: you can re-use the oil if it is not contaminated.

3.10 Gas-ballast inlet connection

As shown in Figure 8 (item 3), the pump has two gas-ballast inlets. We supply the pump with a blanking plug fitted to one inlet: the other inlet is open. You can use either of the inlets, but you must fit the blanking plug to the inlet you do not use.

You can leave the gas-ballast inlet open to the atmosphere. Alternatively, you can fit a gas-ballast control-valve, (available as an accessory, refer to Section 7), for remote control of the gas-ballast supply. In either case, adjust the gas-ballast control (Figure 8, item 5), to regulate the flow rate of the gas-ballast supply.

For more information about the use of gas-ballast, refer to Sections 1.3 and 4.1.

3.11 Leak-test the system

Leak-test the system and seal any leaks found after you have installed the pump, to prevent leakage of substances out of the system and leakage of air into the system.

Pumps International
www.PumpsInt.com

4 OPERATION

4.1 Gas-ballast control

Use the gas-ballast control (Figure 1, item 1) to change the amount of air (or inert gas) introduced into the low-vacuum stage of the pump. Use of the gas-ballast will prevent the condensation of vapours in the pump. The condensed vapours would contaminate the oil.

Turn the gas-ballast control fully clockwise:

- to achieve ultimate vacuum
- to pump dry gases.

Turn the gas-ballast control anti-clockwise to open. Use the gas-ballast control fully open:

- to pump high concentrations of condensable vapour
- to decontaminate the oil.

When you operate the pump with the gas-ballast control open, there is an increased rate of oil loss from the pump.

4.2 Start-up procedure

	<p style="text-align: center;">WARNING</p> <p>Do not block the pump outlet or allow the outlet pressure to rise above 1.5 bar absolute. If you do, the oil box may fracture: this may cause injury to people nearby.</p>
---	---

If the oil is contaminated, or if the pump temperature is below 13°C, or if the supply voltage is more than 10% below the lowest voltage specified for the motor, the pump may operate at reduced speed for a few minutes.

1. Switch on the cooling water supply to the pump.
2. Switch on the electrical supply to the pump.
3. Check that the oil-level in the sight-glass drops slightly (3 to 5 mm) after start-up. This shows that the pump has primed with oil.
4. If the pump fails to prime, operate the pump with the inlet open to atmosphere for approximately 30 seconds. Then isolate the inlet and check that the oil-level drops 3-5 mm.
5. If you want to achieve ultimate vacuum, to pump condensable vapours or to decontaminate the pump oil, refer to the procedures in Section 4.3, 4.4 and 4.5 respectively. Otherwise, open the vacuum system isolation-valve.

4.3 To achieve ultimate vacuum

If the pump does not achieve the performance specified in Section 2, make sure that this is not due to your system design before you contact your supplier or BOC Edwards for advice. In particular, the vapour pressure of all materials used in your vacuum system, including pump oil, must be much lower than the specified ultimate vacuum of the pump. Refer to Sections 5.12.2 for a list of possible causes for failure to achieve the specified performance. The most common causes are:

- Your pressure measurement technique or gauge head is unsuitable or the gauge head is faulty
- You have used an oil other than the recommended oil, and the vapour pressure of the oil is higher than the specified ultimate vacuum of the pump.

Use the following procedure to achieve ultimate vacuum:

1. Isolate the pump from your vacuum system.
2. Turn the gas-ballast control fully anti-clockwise (fully open) and operate the pump for at least 1 hour (or overnight) to thoroughly purge the oil of contaminants.
3. Close the gas-ballast control.
4. Open the vacuum system isolation-valve and pump down to ultimate vacuum.

4.4 To pump condensable vapours

Use gas-ballast when there is a high proportion of condensable vapours in the process gases.

1. Close the vacuum system isolation valve.
2. Turn the gas-ballast control anti-clockwise to fully open and operate the pump for 30 minutes to warm the oil. This will help to prevent vapour condensation in the pump.
3. Open the vacuum system isolation-valve and continue to operate the pump with the gas-ballast control open.

After you have pumped condensable vapours, you can (if necessary) decontaminate the oil. Use the procedure in Section 4.5.

4.5 To decontaminate the oil

The oil in the pump should be clear. If the oil is cloudy or discoloured it is contaminated with process vapours.

1. Look at the condition of the oil in the sight-glass (Figure 1, item 9). If the oil is cloudy or discoloured, continue with the procedure at Step 2 below.
2. Close the vacuum system isolation-valve.
3. Turn the gas-ballast control fully anti-clockwise.
4. Operate the pump until the oil is clear.

4.6 Unattended operation

The pump is designed for unattended operation under the normal operating conditions specified in Section 2. However, we recommend that you check the pump at a regular interval of not more than 14 days. Check the pump more frequently if you pump high volumes of gas or if you operate the pump with the gas-ballast control open.

4.7 Shut-down

Note: If the gas-ballast control is open and the pump is switched off for any reason, the pump drive shaft may rotate in the reverse direction, causing a system pressure rise. To prevent this, use a gas-ballast control valve (refer to Section 7.3.10).

We recommend that you decontaminate the oil before you shut down the pump. Decontamination of the oil will prevent damage to the pump by the contaminants in the oil.

1. Refer to Section 4.5 and decontaminate the oil, as required.
2. Close the vacuum system isolation-valve (if not already closed).
3. Turn gas-ballast control clockwise to close.
4. Switch off the electrical supply to the pump.
5. Close the cooling water supply valve.

Pumps International
www.PumpsInt.com

5 MAINTENANCE

Refer to Section 5.2 recommended maintenance plan.

5.1 Safety



WARNING

Obey the safety instructions given below and take note of appropriate precautions. If you do not, you can cause injury to people and damage to equipment.

- Ensure that maintenance is done by a suitably trained and supervised technician. Obey your local and national safety requirements
- Ensure that the maintenance technician is familiar with the safety procedures which relate to the pump-oil and the products processed by the pumping system
- Check that all the required parts are available and of the correct type before you start work
- Isolate the pump and other components from the electrical supply so that they cannot be operated accidentally
- Allow the pump to cool to a safe temperature before you start maintenance work
- Do not re-use 'O' rings and seals if they are damaged
- After maintenance is completed, recheck the direction of pump rotation if the electrical supply has been disconnected
- Do not touch or inhale the thermal breakdown products of fluorinated materials which may be present if the pump has been heated to 310°C and above. Fluorinated materials are safe in normal use but can decompose into very dangerous substances (which may include hydrofluoric acid) if they are heated to 310°C and above. The pump may have overheated if it was misused or if it was in a fire. Health and Safety Data sheets for fluorinated materials used in the pump are available on request; contact your supplier or BOC Edwards
- Leak-test the system after maintenance work is complete if you have connected or disconnected any vacuum or exhaust joints; seal any leaks found.
- The pump and the pump-oil will be contaminated with the process chemicals that have been pumped during operation. Ensure that the pump is decontaminated before maintenance and that you take adequate precautions to protect people from the effects of dangerous substances if contamination has occurred.
- Ensure all guarding is in place and secure before restarting pump.

5.2 Maintenance plan

The plan shown in Table 2 details the routine maintenance operations necessary to maintain your pump in normal use. Instructions for each operation are given in the section shown.

More frequent maintenance may be required if you use your pump with gas-ballast or to pump corrosive or abrasive gases and vapours. If necessary, adjust the maintenance plan according to your experience.

When you maintain the pump, use BOC Edwards spares and maintenance kits; these contain all of the components necessary to complete maintenance operations successfully. The Item Numbers of the spares and kits are given in Section 7.

Examine the condition of any external accessories, filters or traps (if fitted). Refer to the instructions supplied with these accessories for maintenance procedures.

Operation	Frequency	Refer to Section
Check the oil-level	Weekly	5.3
Replace the oil	6 months	5.4
Clean the fine oil-filter	Every 3000 hours	5.5
Replace the gas-ballast filter	Every 3000 hours	5.6
Inspect and clean the inlet-filter	Yearly	5.7
Clean the motor fan cover	Yearly	5.8
Clean and overhaul the pump	Yearly	5.9
Test the motor condition	Yearly	5.10
Fit new blades	3 years	5.11

Table 2 - Maintenance plan

5.3 Check the oil-level

Note: If required, you can check the oil-level while the pump is operating, however you must switch off the pump and isolate the pump and other components in the pumping system from the electrical supply before you pour oil into the pump.

Refer to Figure 1 for the items in brackets.

1. Check that the oil-level in the sight-glass (9) is between the MAX and MIN level marks indicated on the bezel of the sight-glass (see figure 4).
2. If the oil-level is near to or below the MIN level mark, remove the oil filler-plug (3) and pour more oil into the reservoir until the oil reaches the MAX level mark. If the oil-level goes above the MAX mark, open the oil drain-tap (10) and drain the excess oil from the pump. Refit the oil filler-plug.
3. If the oil is contaminated, drain and refill the pump with clean oil as described in Section 5.4.

5.4 Replace the oil

Refer to Figure 1 for the items in brackets.

1. Operate the pump for approximately ten minutes to warm the oil, then switch off the pump (this lowers the viscosity of the oil and enables it to be drained from the pump more easily).
2. Isolate the pump from your electrical supply and disconnect it from your vacuum system.
3. Remove the oil filler-plug (3).
4. Place a suitable container under the drain-tap (10). Open the drain-tap and allow the oil to drain into the container.
5. If the oil drained from the pump is contaminated, pour clean oil into the filler-hole and allow it to drain out of the pump. Repeat this step until the oil reservoir in the pump has been thoroughly cleaned.
6. Close the drain-tap.
7. Fill a suitable container with clean oil and pour the oil into the filler hole until the oil-level reaches the MAX level mark indicated on the bezel of the sight-glass (9), see figure 4.
8. Allow a few minutes for the oil to drain into the pump. If necessary, add more oil. Refit the filler-plug.
9. Replace the fine oil-filter (see Section 5.5).
10. Replace the gas-ballast filter (see Section 5.6).
11. Reconnect the pump to your vacuum system.
12. Reconnect the electrical supply to your pump.

Pumps International
www.PumpsInt.com

5.5 Clean the fine oil-filter

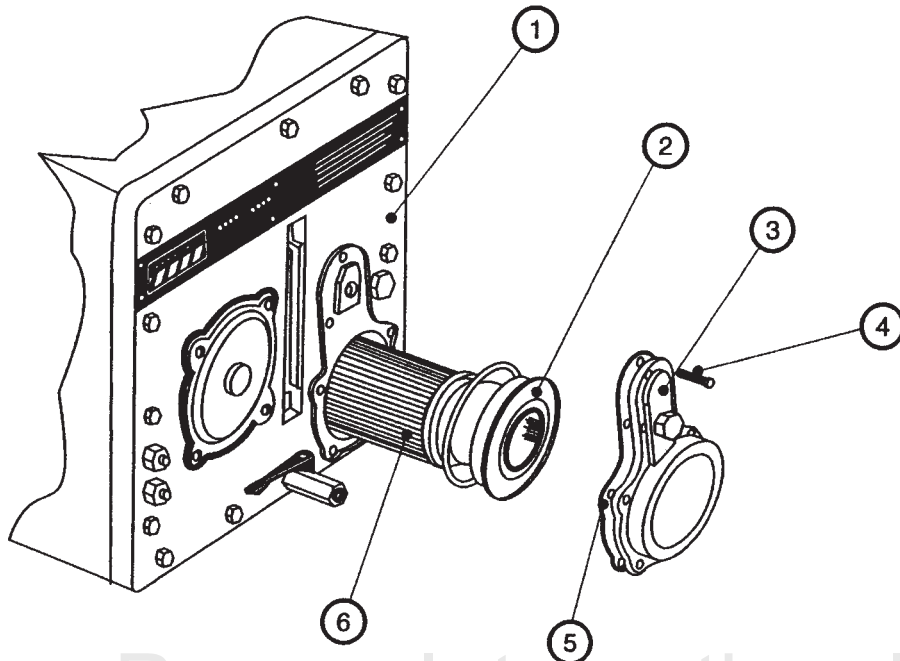

- | | |
|----------------------------|-----------------------------|
| 1. Pump end-plate | 4. Retaining screws |
| 2. Filter-adaptor assembly | 5. Filter head-plate gasket |
| 3. Filter head-plate | 6. Filter-element |

Figure 7 - Remove and replace filter-element

You must clean the fine oil-filter every time you change the oil in the pump. See Figure 7.

1. Isolate the pump from your electrical supply.
2. Drain the pump oil (see Section 5.4).
3. Remove the seven retaining screws (4) from the filter head-plate (3). Remove the filter head-plate and its gasket (5) from the pump end-plate (1).
4. Withdraw the filter-adaptor assembly (2), with filter-element attached, from the pump end-plate.
5. Unscrew the filter-element from the adaptor. Clean the filter-element in a suitable cleansing solution. Allow the filter to dry.
6. Screw the filter-element firmly back into the adaptor (2). Replace the assembly back into the pump end-plate (1) and secure the filter head-plate (3) and its gasket (5) with the seven retaining screws (4).

5.6 Replace the gas-ballast filter

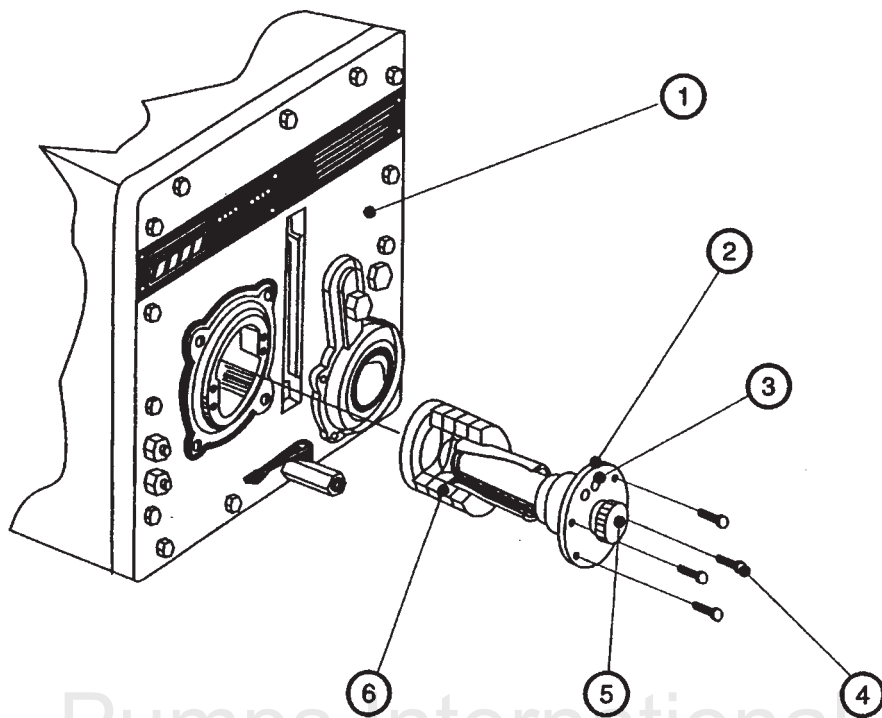

1. Pump end-plate
2. Gas-ballast adjustor-knob bearing-plate
3. Gas-ballast inlets
4. Retaining screws
5. Gas-ballast control
6. Gas-ballast filter-elements

Figure 8 - Remove and replace gas-ballast filter-elements

You must replace the gas-ballast filter-elements every time you change the oil in the pump (see Figure 8).

1. Isolate the pump from your electrical supply.
2. Drain the pump oil (see Section 5.4).
3. Unscrew and remove the four retaining screws (4) securing the gas-ballast adjustor-knob bearing-plate (2).
4. Withdraw the adjustor-knob bearing-plate from the pump end-plate (1).
5. Replace the felt filter-elements (6). There are five for E1M175S/275S (see Figure 8) and two for E2M175S/275S pumps. Clean the assembly before re-fitting new filter-elements by washing in a suitable cleaning solution. Allow the assembly to dry .
6. Fit the filter-elements. Replace the assembly and secure with the four retaining screws (4).
7. Reconnect the electrical supply to your pump.

5.7 Inspect and clean the inlet-filter

You must remove and clean the inlet-filter (positioned in the inlet-port) every time you change the oil in the pump (see Figure 9).

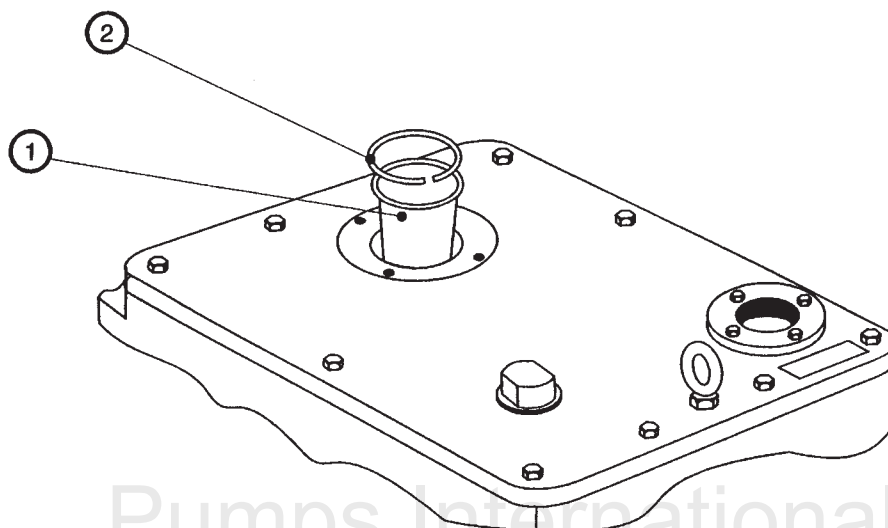

1. Inlet-filter
2. Filter retainer-circlip

Figure 9 - Remove and replace inlet-filter

1. Isolate the pump from your electrical supply.
2. Disconnect the pump from your vacuum system.
3. Remove the filter retainer-circlip (2) and withdraw the inlet-filter (1).
4. Clean the inlet-filter by washing it in a suitable cleaning solution. Allow the filter to dry.
5. Replace items (1) and (2).
6. Reconnect the pump to your vacuum system.
7. Reconnect the electrical supply to your pump.

5.8 Clean the motor fan-cover

You must keep the motor fan-cover clean. Your pump may overheat if the air-flow over the motor is restricted.

1. Isolate the pump from your electrical supply.
2. Use a dry cloth and a brush to remove dirt and deposits from the fan-cover.
3. Reconnect the electrical supply to your pump.

5.9 Clean and overhaul the pump

Clean and overhaul the pump as described in the instructions supplied with the clean and overhaul kit (see Section 7).

5.10 Test the motor condition

Test the earth continuity and the insulation resistance of the pump-motor, in accordance with local regulations for periodic testing of electrical equipment. We recommend that the earth continuity is less than 0.1 W and the insulation resistance is greater than 10 MW. If the motor fails these tests, you must replace the motor.

5.11 Fit new blades

Fit new blades to the pump as described in the instructions supplied with the blade kit (see Section 7).

5.12 Basic fault-finding

A list of fault conditions and their possible causes is provided here to assist you in fault-finding. If you are unable to rectify a fault when you use this guide, call your nearest BOC Edwards Service Centre for help.

5.12.1 The pump has failed to start

- The electrical supply fuse is blown
- The electrical supply voltage does not match the motor
- The outlet pipeline or the outlet-filter (if fitted) is blocked
- The oil temperature is below 12°C
- The oil is too viscous
- The oil is contaminated
- The pump has seized after long storage
- The pump has been left to stand after contaminants have been pumped and has seized
- The motor is faulty.

5.12.2 The pump fails to achieve its specified performance

(Failure to reach ultimate vacuum).

- The measuring technique or gauge is unsuitable
- You have filled the pump with the wrong type of oil
- There is a leak in your vacuum system
- The gas-ballast control is set incorrectly
- The oil-level is low
- The oil is contaminated
- Your vacuum fittings are dirty or damaged
- The inlet-filter is blocked
- The pump has not warmed up
- The pump has failed to prime
- Motor is rotating in the wrong direction.

5.12.3 The pump is noisy

- The motor bearings are worn
- The oil is contaminated with solid particles
- The motor coupling is loose
- A blade is sticking.

5.12.4 The pump is too hot

- The ambient temperature is too high
- The cooling-water supply has an insufficient flow rate
- The electrical supply voltage is too high
- The outlet-filter or the outlet pipeline is blocked
- The oil-level is too low
- You have filled the pump with the wrong type of oil
- The oil is contaminated
- The process gas is too hot or the throughput is too high.

5.12.5 The vacuum is not fully maintained after the pump is switched off

- The gas-ballast control is open
- Damaged or missing 'O' ring
- Anti-suckback valve faulty
- Shaft seals damaged
- Exhaust valve damaged

5.12.6 The pumping speed is poor

- The connecting pipelines are too small in diameter
- The connecting pipelines are too long
- The inlet-filter is blocked

5.12.7 There is an external oil leak

- The oil-pump shaft-seal is worn or damaged
- The oil-box gaskets have deteriorated
- There is an oil leak from the gas-ballast control
- There is an oil leak from the drain-tap
- There is an oil leak from the fine oil-filter element-seal.

Pumps International
www.PumpsInt.com

6 STORAGE AND DISPOSAL

6.1 Storage

CAUTION

Observe the storage temperature limits stated in Section 2. Storage below -30°C will permanently damage the pump seals.

Note: If you will store a new pump in conditions of high humidity, remove the pump from its cardboard packaging box; dispose of the box (refer to Section 6.2).

Use the following procedure to store the pump:

1. Shut-down the pump as described in Section 4.
2. Isolate the pump from the electrical supply.
3. Close cooling water control valve.
4. Disconnect cooling water connections and allow water to drain from the pump.
5. Purge your vacuum system and the pump with dry nitrogen and disconnect the pump from your vacuum system.
6. Replace the oil as described in Section 5.4, paragraphs 3 to 8.
7. Place and secure protective covers over the inlet and outlet-ports.
8. Store the pump in cool, dry conditions until required for use. When required, prepare and install the pump as described in Section 3. If the pump has been stored for more than a year, before you install the pump you must clean and overhaul it as described in the instruction supplied with the clean and overhaul kit.

6.2 Disposal

Dispose of the pump and any components removed from it safely in accordance with all local and national safety and environmental requirements.

You must take particular care with components and waste oil which have been contaminated with dangerous process substances.

Do not incinerate fluoroelastomer seals and 'O' rings.

7 SERVICE, SPARES AND ACCESSORIES

7.1 Introduction

BOC Edwards products, spares and accessories are available from BOC Edwards companies, a world-wide network of distributors is listed at the back page of this document. The majority of these centres employ Service Engineers who have undergone comprehensive BOC Edwards training courses.

Order spare parts and accessories from your nearest BOC Edwards company or distributor. When ordering, please state for each part required:

- Model and Item Number of your equipment
- Serial number (if any)
- Item Number and description of part.

7.2 Service

BOC Edwards products are supported by a worldwide network of BOC Edwards Service Centers. Each Service Center offers a wide range of options including: equipment decontamination; service exchange; repair; rebuild and testing to factory specifications. Equipment which has been serviced, repaired or rebuilt is returned with a full warranty.

Your local Service Centre can also provide BOC Edwards engineers to support on-site maintenance, service or repair of your equipment. For more information about service options, contact your nearest Service Centre or other BOC Edwards company.

7.3 Spares

The following maintenance kits contain all of the parts you will need to maintain your pump. The maintenance kits also include instructions for the use of the kits. Use the Clean and Overhaul Kit for routine maintenance operations. Use the Blade Kit together with the Clean and Overhaul Kit when you must renew the blade assembly in the rotary pump.

Pump	Kit Description	Item Number
E1M175S	Maintenance Kit	A346-01-830
E2M175S	Maintenance Kit	A366-01-830
E1M175S	Seals Kit	A346-01-840
E2M175S	Seals Kit	A366-01-840
E1M175S	Complete Interior Assembly	A346-01-100
E2M175S	Complete Interior Assembly	A366-01-100
E1M275S	Maintenance Kit	A347-01-830
E2M275S	Maintenance Kit	A367-01-830
E1M275S	Seals Kit	A346-01-840
E2M275S	Seals Kit	A366-01-840
E1M275S	Complete Interior Assembly	A347-01-100
E2M275S	Complete Interior Assembly	A367-01-100

7.4 Accessories

A range of accessories is available for the E1M175S, E2M175S, E1M275S and E2M275S pumps.

7.4.1 Inlet dust-filter

The inlet dust-filter is a nylon-fibre filter-element which protects your pump against abrasive dust (see Figure 10, item 1). You can check the filter-element by looking through a glass cover at the top of the filter. The filter is supplied with bolts, washers and 63 mm co-seal.

Product	Item Number
ITF300 Inlet Dust Filter	A442-03-000

7.4.2 Inlet catchpot

The inlet catchpot traps liquid droplets and prevents their entry into the pump (see Figure 10, item 1). You can check the liquid level in the catchpot by looking through a glass cover at the top of the catchpot. The catchpot is supplied with bolts, washers and 63 mm co-seal.

Product	Item Number
ITO300 Inlet Catchpot	A441-03-000

7.4.3 High-capacity inlet dust-filter

The high-capacity inlet dust-filter (see Figure 10, item 1) is a wire mesh filter. You use this filter where you have fast pump down times and where high levels of dust and grit are involved. You can check the filter-element by looking through a glass cover at the top of the filter. The filter is supplied with bolts, washers and 63 mm co-seal.

Product	Item Number
ITM300 High Capacity Dust Filter	A443-03-000

7.4.4 Inlet chemical-trap

The inlet chemical-trap (see Figure 10, item 1) protects your pump against chemically active gases which may attack your pump or pump oil. You must provide the trapping material suitable for your application. The trapping material is contained in a removable fine mesh container supplied with the inlet chemical-trap. You can check the chemical-trap by looking through a glass cover at the top of the chemical trap. The chemical trap is supplied with bolts, washers and 63 mm co-seal.

Product	Item Number
ITC300 Inlet Chemical Trap	A444-03-000

7.4.5 Outlet catchpot

If your pump outlet is piped for remote discharge, condensed pipeline vapour could drain back to your pump. The outlet catchpot (see Figure 10, item 3) collects the liquid. You can see from a sight-glass indication when you need to drain the catchpot. The catchpot is supplied with two ISO40 'C' clamps, ISO40 elbow, two 40 mm centring rings and 'O' rings, bolts, washers, mounting bracket and studs.

Product	Item Number
CP300 Outlet Catchpot	A461-04-000

7.4.6 Outlet mist-filter (clean applications)

The outlet mist-filter (see Figure 10, item 3) collects the oil contained in the oil-mist forming part of the discharge gases. You can monitor the level of oil trapped in the filter, through a sight-glass. This mist-filter must only be used for clean applications. You can return the trapped oil to your pump using the oil return kit. The mist-filter is supplied with two ISO40 'C' clamps, ISO40 elbow, two 40 mm co-seals, bolts, washers, mounting bracket and studs.

Product	Item Number
MF300 Mist Filter	A462-04-000
Clean Application Oil Return Kit	A500-05-000

7.4.7 External oil filter

The external oil filter (see Figure 10, item 2) is a free-standing filter. You can choose between two types of oil-filter. The 'A' series uses an activated earth cartridge which provides chemical cleaning of the oil by removing acidic and other aggressive contaminants. The 'M' series uses a pleated paper cartridge which does not provide chemical filtering but removes abrasive particles down to 0.5 microns. You must check that the external oil filter you choose is suitable for your application.

Product	Item Number
EOF300A External Oil Filter	A500-03-000
Activated Earth Element for EOF300A	A223-04-033
EOF300M External Oil Filter	A500-23-000
Mechanical Filter-element for EOF300M	A223-04-042
EOF300A and M Connection Kit	A364-01-020

7.4.8 Solenoid-operated gas-ballast control valve

The solenoid-operated gas-ballast control valve (see Figure 10, item 5) gives you automatic or remote control of gas-ballast. You can connect the valve to shut off gas-ballast when the pump is switched off and so prevent air from returning to the system.

Product	Item Number
EBV300S Solenoid-Operated Gas-Ballast Control Valve for E1M175S and E1M275S	A500-16-930
EBV300D Solenoid-Operated Gas-Ballast Control Valve for E2M175S and E2M275S	A500-17-930

7.4.9 Thermostatic control valve

The thermostatic control valve (see Figure 10, item 6) promotes rapid pump warm-up and ensures optimum running temperature by controlling cooling-water flow rate. This reduces water usage and running costs and significantly improves vapour pumping performance.

Product	Item Number
TCV300 Thermostatic Control Valve	A500-01-000

7.4.10 Vibration isolators

Use vibration isolators (see Figure 10, item 4) to reduce vibration and noise when the pump is floor or frame-mounted. You must use flexible bellows or other flexible piping between inlet and outlet connections when you fit vibration isolators.

Product	Item Number
Vibration Isolators (set of 4)	A248-01-406

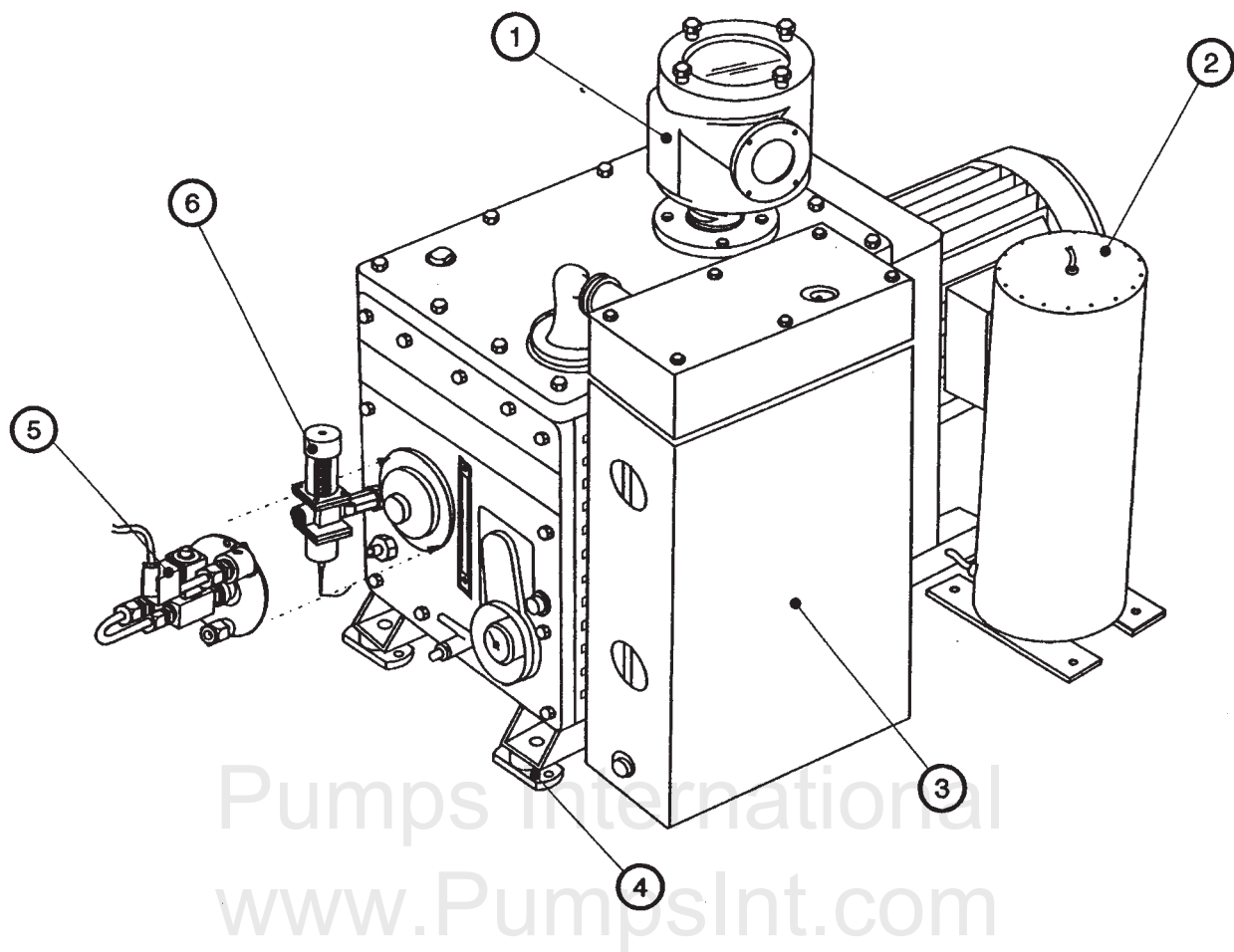

1. Inlet dust-filter or inlet catchpot or high-capacity inlet dust-filter or inlet chemical-trap
2. External oil-filter
3. Outlet catchpot or outlet mist-filter
4. Vibration isolator
5. Solenoid-operated gas-ballast valve
6. Thermostatic control valve

Figure 10 - Accessories

This page intentionally blank

Pumps International
www.PumpsInt.com